



Standards & Specifications

For

The Construction

Of

Distribution Mainlines

2008

Drinking Water You Can Trust

Table of Contents

General	2
1. Project Plans	3
2. Preconstruction Meeting	3
3. Oregon Utility Notification	3
4. Permits and Inspections	3,4
5. Traffic Control	4
6. Separation from other Utilities	4
7. Trench Excavation and Backfill	4,5
a. Excavation	4
b. Trench Shoring & Safety	4
c. Foundation Stabilization	4
d. Pipe Bedding & Pipe Zone	4-5
e. Pipe Backfill	5
1. Class A Backfill	5
2. Class B Backfill	5
3. Class B-AC Backfill	5
8. Pipe Materials & Appurtenances	5-6
a. Pipe Materials	5
b. Fittings	6
1. Compression Couplings & Expansion Joints	6
2. Flanged Couplings	6
3. Valves	6,7
4. Automatic Air Relief Valves	7
5. Valve Boxes	7
6. Fire Hydrants	7
7. Toning Wire	7
8. Misc Small fittings	7
9. Pipe Installation	7-8
10. Concrete Thrust Blocking	8
11. Surface Restoration	8
12. Testing and Disinfection	8-9
a. Testing	8-9
b. Disinfection	10
13. Acceptance of Water Line	11
14. Warranty of Work	11
15. Cross Connection Control and Backflow Assemblies	11
16. General Water Line Construction Notes	12
List of Figures	
A. Typical Meter Set	13
B. Typical Blow Off	14
C. Ditch Profile	15
D. Typical Air Relief	16
E. Inline Valve	17
F. Typical Hydrant Detail	18
G. Thrust Blocking	19
H. Tie In Detail	20

General

Umpqua Basin Water Association is a private non-profit cooperative that operates a treatment plant and distribution system as similar to a public utility. UBWA is responsible for providing safe and reliable production and distribution of drinking water to its members.

These standards are intended to protect the integrity of the existing system and ensure the future systems operate efficiently. UBWA reserves the right to approve or reject any materials and devices proposed to be installed into the water system. UBWA also reserves the right to require that any proposed addition(s) to the water system comply with reliability, redundancy, construction, and capacity requirements as outlined in these standards.

The Standards and Specifications for the design and construction of water production and distribution must comply with the minimum requirements set forth by Umpqua Basin Water Association.

The standard specifications which are applicable to these special provisions are those entitled as follows called the Standard Specification except as the same may be modified, supplemented, or superseded by the special provision herein contained.

All design and construction of water production and distribution projects will comply with all local, state, and federal standards such as:

- a) The current Oregon Revised Statutes.
- b) The Oregon Health Division, Drinking Water Section, of the Oregon Administrative Rules.
- c) The current American Water Works Association (AWWA) Standards for the design and construction of public water systems.
- d) The Technical Specifications, which are applicable to the work on a project, are the 2008 edition of the Oregon Standard Specifications for Construction by the Oregon Department of Transportation/APWA, Oregon Chapter and the Special Provisions herein.

The 2008 edition of the ODOT Standard Specifications for Construction are not bound herein and may be purchased from the Oregon Department of Transportation, Contractor Plans, 355 Capitol Street NE, Room 28, Salem, Oregon, 97301 / (503) 986-6936 or http://www.oregon.gov/ODOT/HWY/SPECS/standard_specifications.shtml

1. Project Plans

UBWA requires prior to construction (one) 1 set of completed project plans for audit and corrections, and (two) 2 sets of finished projects plans. UBWA, the contractor and/or each sub-contractor shall have a minimum of one set of approved construction plans on the job site at all times during each construction phase while work is being done. The contractor shall perform all the work shown on the drawings and all incidental work considered necessary to complete the project in an acceptable manner

2. Preconstruction Meeting

A preconstruction meeting is required prior to any construction involving a tie-in to any water line owned by UBWA. This meeting will take place at minimum of five (5) days prior to any and all work within the jurisdictions of UBWA.

3. Oregon Utility Notification

The contractor shall notify UBWA at least 48 hours (two full working days) prior to beginning the project. Connections between existing infrastructures and new work shall not be made until necessary inspections and tests have been completed on the new work and it is found to conform in all respects to the requirements of the plans and specifications. No connections or interruptions of service to the existing UBWA lines shall be done on a Monday and or Friday. All connections or interruptions of service to existing UBWA lines shall be done on Tuesday through Thursday starting not earlier or later than nine (9) am.

In order to protect existing underground utilities, Oregon law requires all excavators to follow rules adopted by the Oregon Utility Notification Center. Those rules are set forth in [OAR 952-001-0010](#) through [OAR 952-001-0090](#). You may obtain copies of the rules by calling the center

Contractors performing work shown on the plans must notify utilities and public agencies at least 48 business hours in advance of, and no more than 10 business days before, beginning excavation, in accordance with the provisions set forth in OAR [952-001-0010](#) through [OAR 952-001-0090](#). Call the One Call Utility Notification Center at 800-332-2344 for utility locates.

Existing utility locations are approximate only. Limits of work shall be pre-marked for the utility locators. Pothole all crossings as necessary to prevent grade and alignment conflicts. Report all conflicts to UBWA or onsite Engineer immediately. Protect existing utilities at all times during construction. Any movement or damage to existing utilities, whether they are shown on the drawings or not, will be repaired or replaced at the developer or contractor's expense.

The contractor shall exercise all due care in protecting property along the route of the improvements. This protection shall include, but not be limited to, trees, yards, fences, drainage lines, mail boxes, driveways, shrubs, lawns, irrigation systems, within any rights-of-ways and easements. If any of the above have been disturbed, they shall be restored as necessary to as near their original condition as possible or replaced in kind.

4. Permits and Inspections

All permits and fees to complete the project shall be the responsibility of the contractor.

Operation of existing valves shall be performed only by authorized UBWA staff.

Waterlines shall be inspected and tested as required by UBWA and or onsite Engineer and in conjunction with applicable codes and specification prior to backfilling. The Contractor shall

arrange for all inspections and tests which are required by the codes or ordinances during construction.

5. Traffic Control and Safety

Contractor shall be responsible and shall comply with all State and Federal agency requirements for traffic control and safety. Proper implements, tools, and construction methods shall be used by the contractor for the safe and proper execution of the work or as specified in [section 00225](#).

6. Separation from other Utilities

Water line construction shall comply with regulations of the Oregon Department of Human Services <http://oregon.gov/DHS/ph/dwp/rules.shtml> regarding the location and separation of water lines and sanitary sewer lines. Separation requirements can be accessed at <http://oregon.gov/DHS/ph/dwp/docs/pwsrules/61-0050.pdf>.

Water main lines shall have a minimum horizontal separation from all other utilities of five (5) feet, unless otherwise approved by Umpqua Basin Water Association, Inc. Without exception, no utility shall be placed vertically above or below parallel to the water main line.

7. Trench Excavation and Backfill:

a. Excavation

Saw cut all bituminous or concrete pavements, sidewalks, or curbs per [section 00405](#) of the Standard Specifications prior to excavation of the trench.

Trench excavation is defined as the removal of all material encountered in the trench to the depths as shown or directed by the Engineer. Trench excavation shall be classified as either common or rock excavation as defined in [section 00405](#) of the Standard Specifications.

b. Trench Shoring & Safety

The Contractor shall be responsible and shall comply with all State and Federal agency requirements for trench shoring and safety. Proper implements, tools, and construction methods shall be used by the contractor for the safe and proper execution of the work.

c. Foundation Stabilization

Foundation stabilization material shall be placed under the waterlines whenever soft ground conditions are encountered that are not beneficial to proper installation, and in such quantity as is required to stabilize the trench bottom.

Foundation stabilization material shall be compacted to 95% of the maximum dry density and shall be tested as specified in [section 00405](#), "Trench Backfill".

Bell holes shall be provided at each joint to permit the joint to be properly made, to permit easy inspection of the joint, and to provide uniform bearing for the entire pipe length.

d. Pipe Bedding & Pipe Zone

Pipe bedding and pipe zone materials under and around the pipe shall be free of sticks, or other deleterious material and shall consist of ¾" minus crushed quarry rock and shall be placed under, around and above pipe as detailed in the ditch profile drawings as to provide and firm, smooth, and uniform support for the full pipe zone.

The pipe bedding and pipe zone material shall be placed in lifts as shown in the "Trench Detail" and compacted to 95 percent of maximum density as obtained by AASTO T-99 compaction test.

e. Pipe Backfill

The contractor shall be responsible for prompt surface restoration and continuous repair of settlement during construction. When pipe installation would cause excess material to be on roadways, the Contractor shall remove the excess material to provide a clear, smooth, unobstructed roadway surface.

All backfill in the right of way or other traffic areas shall be ¾" minus compacted crushed rock, compacted to 95 percent of maximum density as obtained by AASTO T-99 compaction test.

All pipes shall have 36" minimum cover measured from finish grade unless specifically noted for less cover with mitigating measures.

1. Class A backfill - shall consist of native material, free of stones over 4" in diameter, sticks, or other deleterious material; and shall contain proper moisture for compaction as specified in [section 00405](#) of the Standard Specifications. Materials excavated from the trench that is unsuitable for backfill shall be removed and disposed of by the contractor, and suitable material imported.
2. Class B - backfill shall consist of ¾" minus crushed quarry rock and shall be placed within any improved area. Class B backfill shall be mechanically compacted as specified in [section 00405](#) of the Standard Specifications.
3. Class B-AC - backfill shall be defined as any backfill within a previously paved area or roadway. Backfill material and placement shall be as specified for Class B backfill or sand slurry where required by the Engineer.

If in the opinion of the Engineer, the methods utilized by the Contractor for placing and compaction of foundation stabilization, pipe bedding, pipe zone, or asphalt-concrete pavement materials are not achieving the degree of compaction as specified, a compaction test or tests will be ordered by the Engineer. Should the tests indicate insufficient compaction, the contractor shall re-compact the trench and pay all associated testing cost for each test that fails to meet the requirement of the specifications.

8. Pipe Materials and Appurtenances

a. Pipe Materials

All materials and workmanship shall exceed and or comply with AWWA, UBWA, and the Uniform Plumbing Code as applicable. All material shall be of new manufacture. No rebuilt or used materials will be allowed.

The contractor certifies that all materials delivered to the job site will meet or exceed AWWA, UBWA or other applicable specifications. Any material not conforming shall be removed from the site and replaced at no additional cost to the owner.

Ductile Iron Pipe – shall be a minimum size of 8" and conform to AWWA C151/A21.51-96, class 52, cement mortar lining and bituminous seal coat shall conform to AWWA C104/A21.4-95, Joints to be push-on mechanical seal, conforming to AWWA C111/A21.11-00 or latest revision.

b. Fittings

Fittings shall consist of all bends, crosses, elbows, and other appurtenances required for the project. Special note should be taken at the end configuration of the various fittings as required on the plans for various installation conditions. All fittings shall be mechanical joint or flanged except as otherwise approved by UBWA.

Ductile iron fittings for ductile iron pipe shall meet the requirements for the class 200 cast iron pipe, Federal Specifications WW-P-421 or for class D cast iron pipe and fittings conforming to ANSI/AWWA C110/A21.10-98 or latest revision.

Body dimensions shall be of the short type bell construction and shall be designed for use with molded tubular rubber rings conforming to ANSI/AWWA Specifications C111/A21.11-00, or latest revision.

Mechanical joint fitting bells shall be cast integrally with the pipe or fittings and provided with an exterior flange having bolt holes or slots and a socket with annular recesses for the sealing gasket and the plain end of the pipe or fittings. Mechanical joint assemblies shall include a sealing gasket, a follower gland with bolt holes, a retainer gland with bolt holes when shown on the plans and standard tee-head bolts and hexagonal nuts. Mechanical joint fitting shall be utilized with cast iron outside diameter. All mechanical joint fittings shall have restraint type follower glands such as EBAA (Megalug) or Romac (RomaGRIP) brand locking restraint follower glands, or UBWA approved equal.

Flange type joint flanges and bolts shall conform to ASA B16.1. All bolts and nuts shall be cadmium with screwed flanges or standard flanged joints where practical flanged fittings shall conform to ASA B16.1, Class 125 or Class 250, unless otherwise specified. Gasket material for flange joints shall be sheet rubber conforming to Federal Specification HH-G-156, Class A or Class B, 1/8" thick, or as approved. The gasket shall be full cut with holes to pass bolts.

1. Compression Couplings & Expansion Joints

Compression coupling for the use with ductile iron pipe shall be Romac #501 or Smith Blair #441. Rubber expansion joints for the use with ductile iron fittings shall be Belmont Spool type #5201 or approved equal.

2. Flanged Couplings

Flange coupling adapters for the use with ductile iron pipe shall be Smith Blair #912, Romac FCA501 or approved equal.

3. Valves

Valves shall be resilient seat, non-rising stem conforming to ANSI/AWWA C509-94 or latest revision. All valves shall be rated for 200 psi working pressure, 350 psi test pressure, and furnished with "O-Ring" stem seals.

Valves shall have mechanical joint ends unless otherwise shown on plans or details. All valves shall have a 2" square operating nut.

All Valves placed in the service line or main line will be at a maximum distance of 800' as specified by in the standards of AWWA.

Valves shall be Kennedy, M & H, Mueller, or approved equal.

All brass gate valves shall be of NIBCO brand.

4. Automatic Air Relief Valves

Air relief valves shall be APCO #143-C-1, Val Matic #201-C-1, or approved equal. Air relief valves shall be installed in the configuration and location specified by UBWA or onsite Engineer. Air relief valves shall have screened outlets to prevent infiltration.

5. Valve Boxes

Valve boxes shall be cast iron with adjustable length, three piece configuration for varying installation conditions. Valve box shaft shall be 5-7/8" diameter with cover lettered "WATER".

Valve boxes shall be Rich #926 with deep well base of appropriate length for installation, or approved equal.

6. Fire Hydrants

All fire hydrants shall conform to ANSI/AWWA C502-94 or latest revision. Hydrants shall be 5-1/4" size. Hydrants to be Mueller-Centurion, Kennedy, approved equal and or shall conform to the accepted brands and models as required by the local fire district. Fire hydrants shall be located to allow a minimum of 36" clear space surrounding all portions of the hydrant. There shall also be no obstructions directly in line with any of the ports of the hydrant for a distance of 6 feet.

7. Toning Wire

Toning wire shall be a single solid #14 AWG UF wire for direct burial use.

8. Misc. Small fittings

All small fitting shall be domestic brass. All service fittings shall be Ford Q compression style brass unless otherwise specified by UBWA.

9. Pipe Installation

All Ductile Iron pipe and fittings shall be installed and assembled according to the manufacturer's written recommendations and to ANSI/AWWA C600-99 or the latest revision for ductile iron pipe.

All pipe and fittings shall be inspected by the Contractor for defects prior to installation. No scored, cracked, broken, or defective pipe or fittings shall be allowed. All pipe and fittings shall be cleaned before installation. No debris, tools, or other foreign materials shall be allowed inside the pipe. All pipe and fittings shall be carefully lowered into the trench. Dropping of pipe or fittings is prohibited. All defective pipe and fittings will be removed from the project site immediately by the contractor and replaced at no additional expense to the owner. The Contractor is responsible for any and all damage to pipe prior to acceptance by UBWA or onsite Engineer and shall reinstall pipe that does not meet specifications or was damaged during installation at no additional expense to the owner.

The Contractor shall maintain means of removing and disposing of all water in the trench without causing damage to adjacent property. No water shall be allowed in the trench during construction.

All pipe and fittings shall be installed per lines and grades on the plans or established by the Engineer. Maximum deflection at any joint shall not exceed (3°) degrees for ductile iron pipe.

The maximum deflection shall not exceed the manufacturer's recommendation for the particular class of pipe to be installed.

Toning wire shall be buried the entire length of the trench and shall be located over the pipe zone bedding material approximately six (6") inches above the top of the pipe. The toning wire shall be brought to the surface at the wire ends, valves, and hydrants. Wire shall be brought up in 1-1/2" PVC with a cap on the top or up the outside of the valve box to within six (6) inches of the ground surface then brought into the inside of the valve box.

Contractor shall take all necessary pre-cautions to prevent uplift of any piping or fittings. All pipe and fittings shall be sealed at the end of the working day to prevent any foreign matter from entering the pipe.

Install all valve, valve boxes, fittings, hydrants, and support valves, plumb and true as shown on the plans. All valves shall be installed with the cast iron valve box centered over the valve operation nut.

All water service laterals are to be installed by the developer in accordance with UBWA and AWWA Standards.

10. Concrete Thrust Blocking

In the addition to restrained joints, concrete thrust blocking shall be provided at all tees, bends, and ends of waterlines where required to prevent movement. Thrust blocking sizes and configuration for various fittings to be per standard specification thrust blocking details. All thrust blocking to be placed so that the pipe and fitting joints will be accessible for repair. All thrust blocking shall have a minimum of six (6) mil protective sheeting between blocking and tees, bends, pipe ends and fittings.

All thrust blocking shall be of at least 3000 psi concrete. The area of holding surface required shall be computed on the soil having a side bearing value of 1000 lbs/s.f. and a working pressure of 200 psi.

11. Surface Restoration

Surface restoration shall comply with [section 00405](#) of the Standard Specifications. The Contractor shall maintain all surface areas for a period of one year, and will furnish all required materials after the completion of the initial project.

Surface restoration for Class B-AC backfill shall be 4" or thickness equal to the removed pavement, whichever is greater of Class C asphalt concrete pavement as specified in [section 00744](#) of the Standard Specifications.

12. Testing and Disinfection

a. Testing

Upon completion of installation of the water system, all lines shall be flushed, disinfected, and tested in conformance with AWWA (C605-94 sec 7.1- 7.4) and DHS guidelines and the requirements of the Oregon Department of Environmental Quality.

Water mainline shall be hydrostatically tested at 200 psi. The duration of the hydrostatic test shall be two (2) hours with a maximum allowable pressure loss of 5 psi, unless otherwise directed by UBWA or onsite Engineer. The contractor shall furnish and operate all pumps, gauges, plugs, saddles, corporation stops,

miscellaneous hose and piping, and measuring equipment necessary for performing the test. The contractor shall provide certifications of accuracy for gauges used in the test from an approved laboratory.

The contractor shall backfill the pipeline sufficiently to prevent movement of the pipe under pressure. The contractor shall place all thrust blocks to allow time for the concrete to cure before testing. Where permanent blocking is not required, the contractor shall furnish and install temporary blocking and remove it after testing.

The contractor shall fill the mains with water and allow to stand under pressure a sufficient length of time to allow the escape of air and to allow the lining of the pipe to absorb water. UBWA will furnish the water necessary to fill the pipelines for testing, at a time of day when sufficient quantities of water are available for normal system operation.

The contractor shall test by pumping the main up to the required pressure for at least two hours and shall provide additional pumping as necessary during the test period to continuously maintain pressure within 5 psi of that required. During the test, observe the section being tested to detect any visible leakage. Use a clean container to hold water for pumping up pressure on the main being tested. Sterilize this makeup water by adding chlorine to a concentration of 25 mg/L.

The contractor shall accurately determine the quantity of water required to maintain and restore the required pressure at the end of the test period by pumping through an approved positive displacement water meter.

The quantity of water lost from the main shall not exceed the number L/h (gallons per hour) determined by the formula:

ENGLISH

$$L = \frac{ND(P)^{1/2}}{7400}$$

where:

- L = allowable leakage in gallons per hour
- N = number of joints in the length of the pipeline tested
- D = nominal diameter of the pipe in inches
- P = average test pressure during the leakage test in psi

There shall be no appreciable or abrupt loss in pressure during the test period.

The contractor shall correct any visible leakage regardless of the allowable leakage as specified above. Should the actual leakage exceed the allowable amount, the contractor shall locate and repair the leaks and retest the pipeline.

Make all test with the hydrant auxiliary gate valve open and pressure test against the hydrant valve. After the pipe test has been completed, test each gate valve in turn by closing it and relieving the pressure beyond. This test of the gate valve will be acceptable if there is no immediate loss of pressure on the gauge when the pressure beyond the valve is relieved.

Verify that the pressure differential across the valve does not exceed the rated working pressure of the valve.

Limit section to be test to 1500 feet, unless longer test section is approved by UBWA or onsite Engineer. UBWA or onsite Engineer may require that the first installed section of pipe installed by each crew, not less than 1000 feet in length, be tested. Do not continue pipe laying more than an additional 1000 feet until the first section has been tested successfully.

Prior to calling out UBWA or Engineer to witness the pressure test, set up all equipment completely ready for operation and successfully perform the test to ensure that the pipe is in a satisfactory condition.

Replace defective materials or workmanship discovered during hydrostatic field testing. Whenever it is necessary to replace defective material or correct the workmanship, repeat the hydrostatic field test until satisfactory test is obtained.

b. Disinfection

All water lines shall be disinfected according to AWWA Specifications C651-92 by the Contractor prior to connection to the Owner's existing system. During the disinfection process, all valves in the water line shall be operated by the Owner's representative.

Initial dosages of chlorine shall be injected into the water line to provide a dosage of at least 40 parts per million (ppm). Treated water shall be retained in the water line for at least twenty-four (24) hours. A free chlorine residual of not less than 10 ppm shall be maintained in all parts of the water line after the 24-hour period has elapsed. During the disinfection process, all valves in the water line shall be operated, and blow-offs flushed until a strong residual is found.

Disinfectant shall be either a liquid chlorine-water mixture, direct fed chlorine gas, or a calcium hypochlorite and water solution, as directed in AWWA Specification C651-92.

After the 24-hour disinfection time period, the highly chlorinated water shall be flushed from the line until the residual chlorine dosages are equal to those in the existing water system. Highly chlorinated water flushed from the line shall be disposed of in accordance to all County, State and Federal regulations.

Water samples shall be taken at various points along the water line as determined by UBWA or onsite Engineer to ensure all portions of the water line have been properly disinfected. Test results shall be submitted by the contractor at the expense of the developer, to Umpqua Basin Water Association and approved before consumer usage will be allowed.

13. Acceptance of Water Lines

Prior to receiving written acceptance, UBWA will conduct an inspection of all aspects of the project including clean-up. Following substantial completion, the developer's Engineer shall provide three paper-copies, one PDF copy and one copy as a dwg file, of As-Builts and Record drawing sets of all sheets plus any approved revisions. Subsequent to receiving the written acceptance from UBWA and no later than thirty (30) days from the date of acceptance, the owner or developer will furnish a letter to UBWA with the final cost incurred with the installation of the new water line.

Project acceptance shall consist of a written document stating the warranty period that the said contractor has completed the said contract and has met all obligations, requirements, and specifications set forth by Umpqua Basin Water Association, Inc.

14. Warranty of Work

The contractor shall guarantee the water line materials and workmanship for a period of one (1) year commencing from the time of the projects acceptance by Umpqua Basin Water Association, Inc. per the requirements of [section 00170.85\(b\)\(2\)](#). Any services provided by UBWA or work performed by UBWA during the warranty period will be billed to the developer or owner.

15. Cross Connection Control and Backflow Assemblies

When required, backflow prevention assemblies for the protection of the public water system shall meet the requirements set forth in the current Oregon Administrative Rules Chapter [333-061-0070](#), Uniform Plumbing Code.

For further information contact the UBWA Backflow Specialist for more information at 541-672-5559.

GENERAL WATERLINE CONSTRUCTION NOTES

1. ALL MATERIALS AND WORKMANSHIP SHALL COMPLY WITH AWWA STANDARD SPECIFICATIONS AND THE UMPQUA BASIN WATER ASSOCIATION, INC. STANDARDS & SPECIFICATIONS. IN CASE OF CONFLICT, UBWA SPECIFICATIONS SHALL TAKE PRECEDENCE. DEVELOPER SHALL WARRANT WATERLINE FOR ONE (1) YEAR AFTER ACCEPTANCE.
2. PIPE FOR WATER MAINS SHALL BE AS SHOWN ON PLANS & SPECIFICATIONS.
3. VALVES SHALL BE RESILIENT SEAT GATE VALVES, PER ANSI/AWWA C509-94. AND SUPPORTED WITH A SOLID PRECAST BASE BLOCK.
4. FITTINGS SHALL BE DUCTILE IRON PER AWWA C-110, 250 P.S.I. RATING, WITH MECHANICAL JOINT OR FLANGED ENDS, AS DETAILED.
5. ALL LATERAL SERVICE LINES WILL BE ENCLOSED WITH IN AN APPROPRIATE TYPE AN SIZE OF CASING.
6. PIPE BEDDING SHALL BE 3/4" MINUS CRUSHED ROCK PER THE AWWA STANDARD SPECIFICATIONS.
7. BACKFILL FOR PIPE SHALL BE CLASS "A" (COMPACTED EXCAVATED MATERIAL), CLASS "B" (3/4" MINUS CRUSHED ROCK), OR SAND SLURRY AS SHOWN ON CONSTRUCTION PLANS.
8. TONING WIRE, INSULATED FOR IN-GROUND USE SHALL BE INSTALLED DIRECTLY OVER ALL WATER MAINS AND SERVICE LINE INSTALLATIONS. WIRE SHALL BE BROUGHT TO THE SURFACE AT ALL VALVES, FIRE HYDRANTS AND METER BOXES. SPLICES FROM MAIN LINE TO SERVICE LINE TONING WIRE SHALL BE MADE WITH 3M-DIRECT BURY SPLICE KITS DESIGNED FOR IN-GROUND USE.
9. COMPLETED WATER LINE INSTALLATION SHALL BE FLUSHED AND PRESSURE TESTED IN ACCORDANCE WITH THE STANDARD SPECIFICATIONS. COMPLETED WATER LINE INSTALLATION SHALL BE CHLORINATED AND TESTED FOR BACTERIA IN ACCORDANCE WITH THE REQUIREMENTS OF ORS 333.61.056(11). THE ENGINEER AND UMPQUA BASIN WATER ASSOCIATION, INC. REPRESENTATIVE SHALL BE PRESENT FOR TESTING.
10. METER LOCATION TO BE MARKED FOR HORIZONTAL & VERTICAL ALIGNMENT.
11. ALL WATER LINES SHALL BE COVERED WHILE AN ASSOCIATION INSPECTOR IS PRESENT.
12. NO OTHER UTILITY SHALL RUN PARALLEL WITHIN 5 FEET OF NEW WATER MAINS.
13. SANITARY SEWER MAINS AND LATERAL WHICH CROSS WATER MAIN LINES SHALL CONFORM TO OREGON HEALTH DIVISION ADMINISTRATIVE RULES, CHAPTER 333, PUBLIC WATER SYSTEMS.
14. ALL MECHANICAL JOINT FITTINGS SHALL HAVE MECHANICAL JOINT RESTRAINTS IN ADDITION TO THRUST BLOCKS.
15. THRUST BLOCKS SHALL BE INSTALLED AT ALL BENDS AND FITTINGS PER THE STANDARD DRAWING.
16. MINIMUM COVER FOR WATER MAIN LINES IS 36" INCHES UNLESS DIRECTED BY ENGINEER OR UBWA REPRESENTATIVE.
17. THE CONTRACTOR IS REQUIRED TO TAP THE PIPE AND INSTALL THE APPROPRIATE SADDLE AND CORP STOP RECOMMENDED BY UMPQUA BASIN WATER ASSOC., INC.
18. ALL WATER LINES WILL BE AT MINMUM CLASS 52, 8" DUCTILE IRON PIPE.
19. UMPQUA BASIN WATER SHALL BE GIVEN 24 HOURS NOTICE BEFORE ANY WORK SHALL BEGIN.
20. NO LINE INSTALLATION WILL BE PEERFORMED ON A MONDAY OR FRIDAY AND ALL TIE-INS WILL BE START NO SOONER THAN 9:00AM.
21. A SET OF COMPLETED AS-BUILTS WILL BE DELIVERED TO UBWA WITH IN TWO WEEKS OF LINE ACCEPTANCE. THE FORMAT FOR THE AS-BUILTS WILL BE; THREE PAPER COPIES, ONE COPY AS A PDF AND ONE COPY AS A DWG FILE.

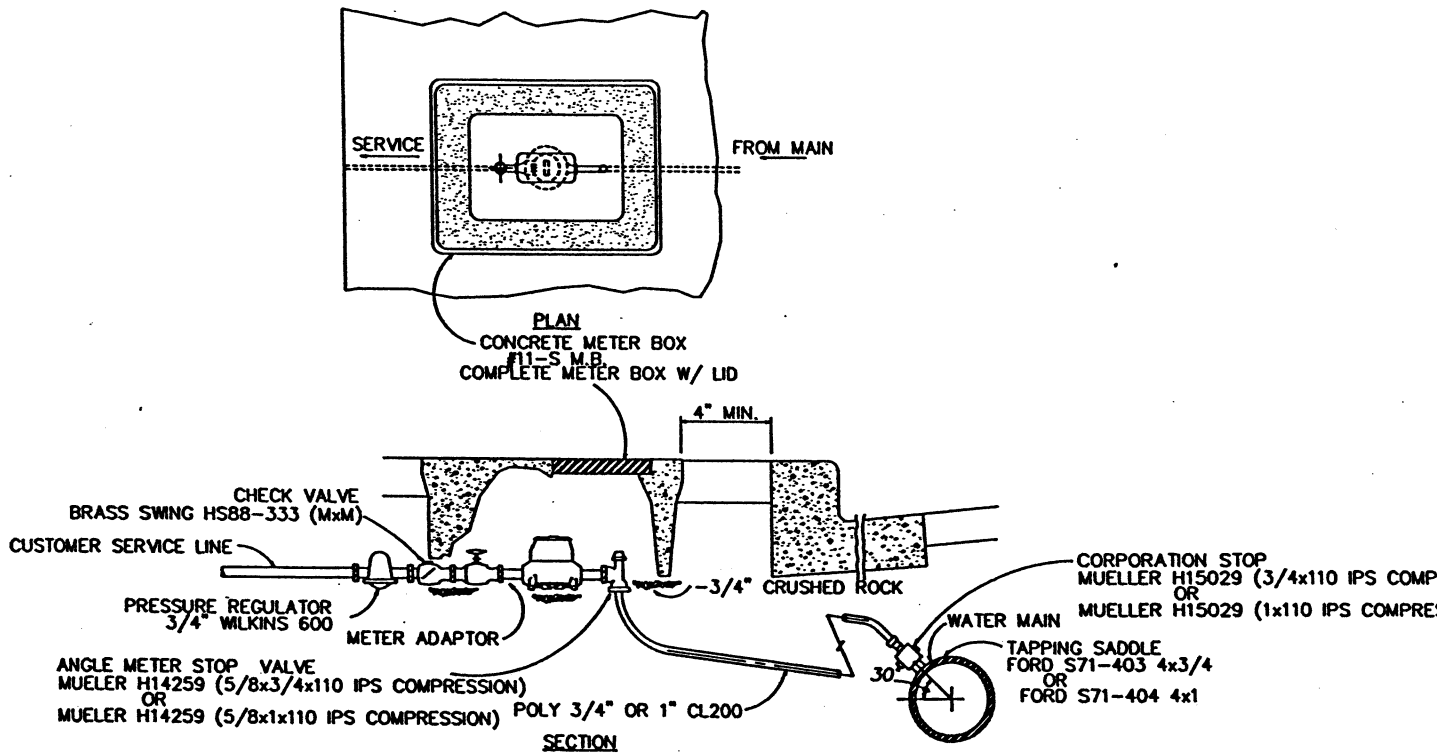

NOTES:

1. METER TO BE CENTERED AND SET PLUMB INSIDE METER BOX.

3/4" TO 2" WATER METER SETTING

Typical Meter Set

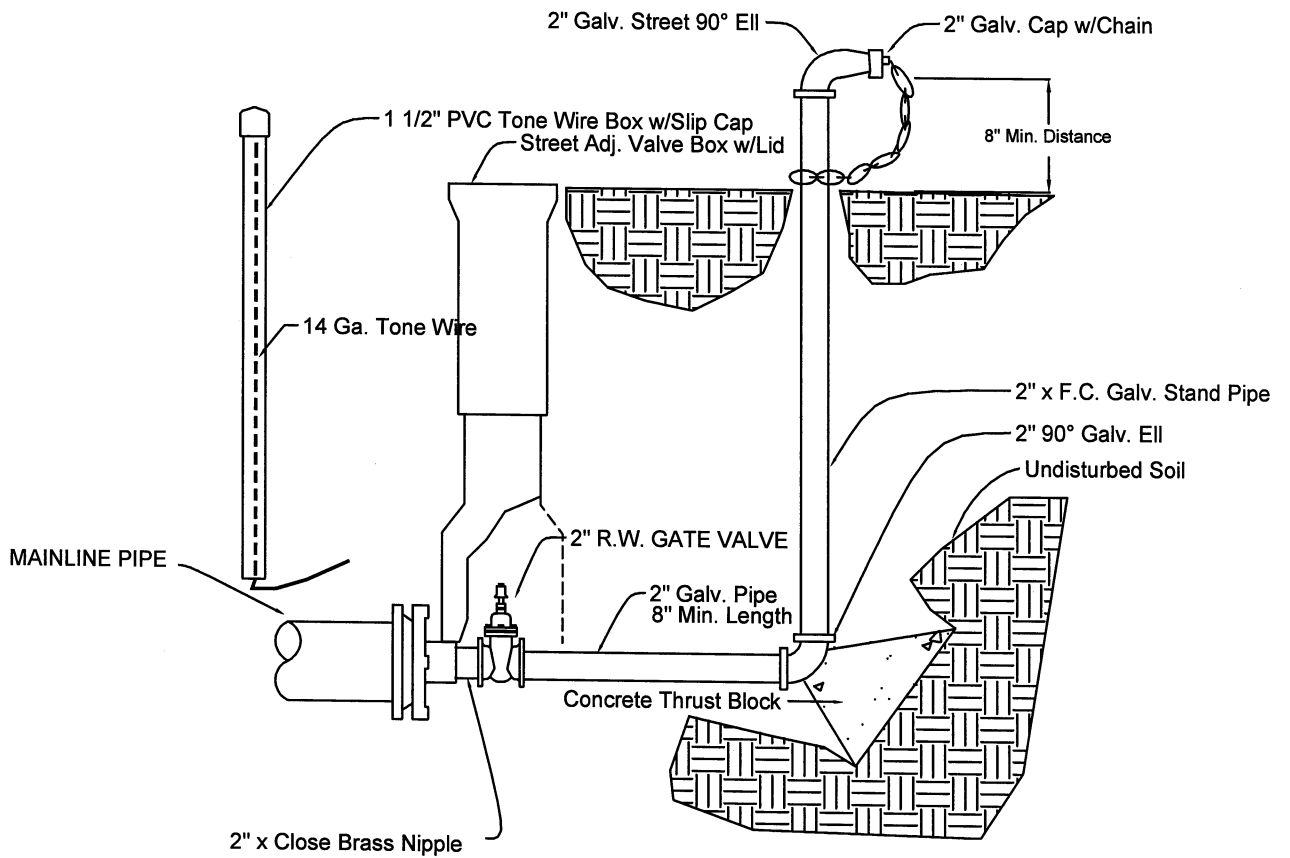

Typical Blowoff Assy.

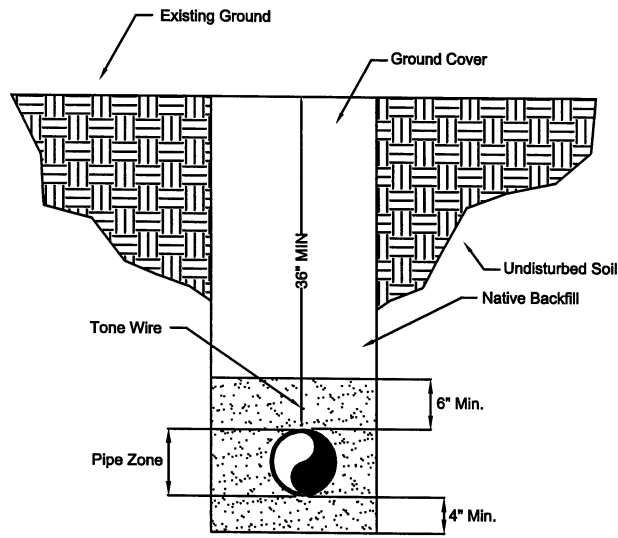

Ditch Profile Class "A"

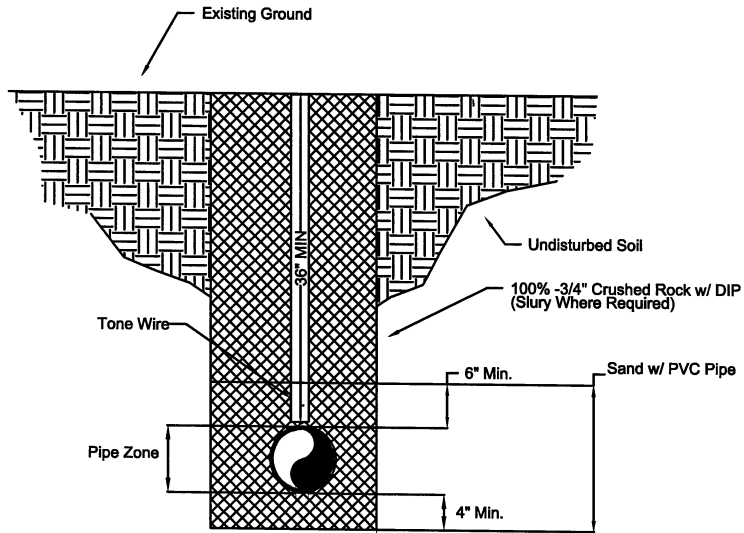

Ditch Profile Class "B"

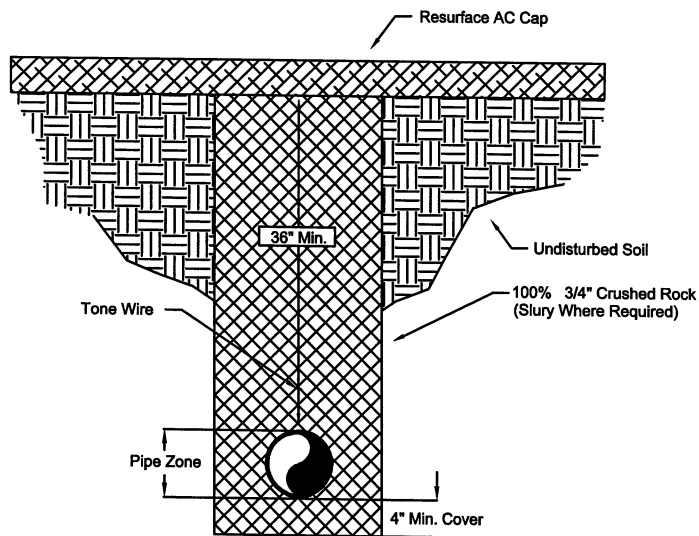

Ditch Profile Class "B-AC"

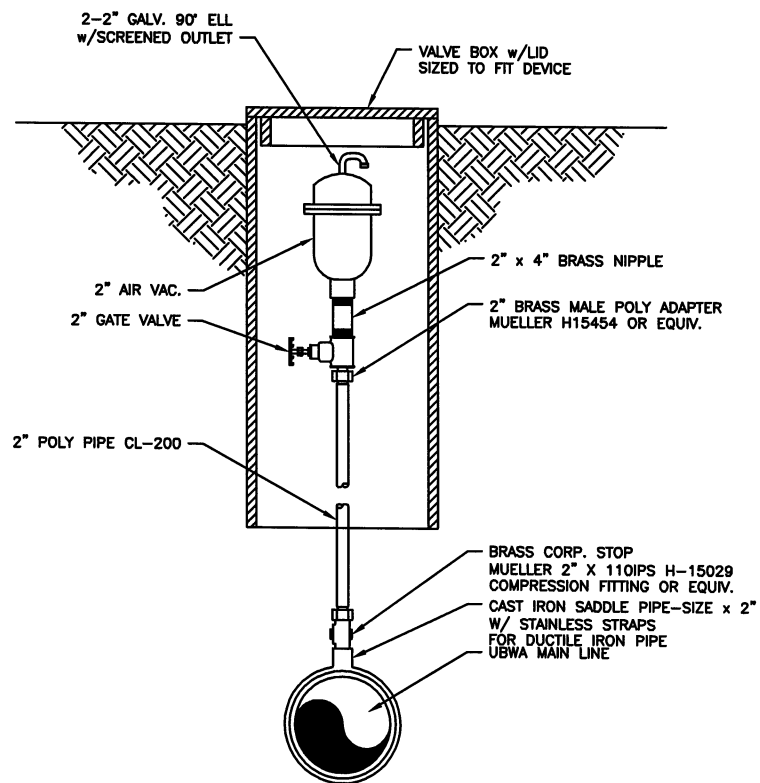

TYPICAL AIR RELIEF DETAIL

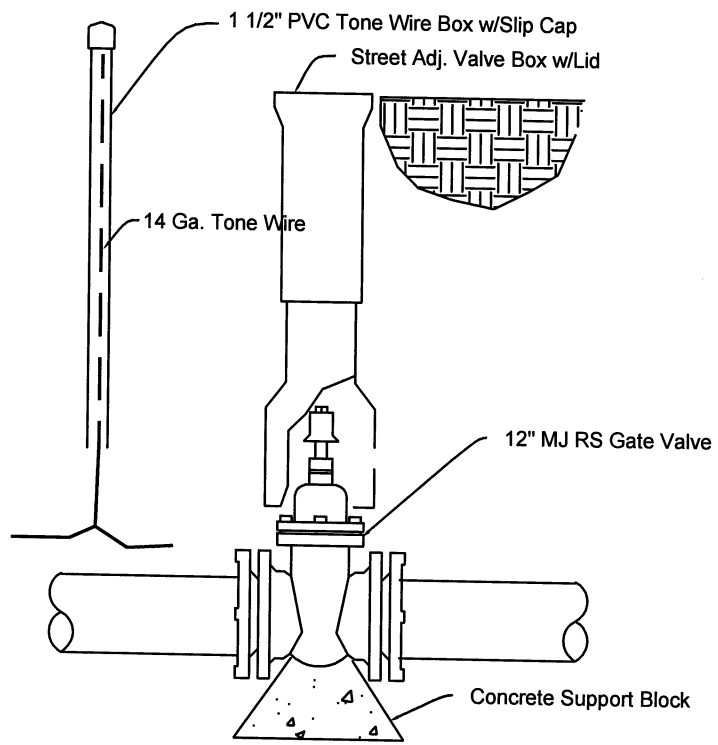

INLINE VALVE DETAIL

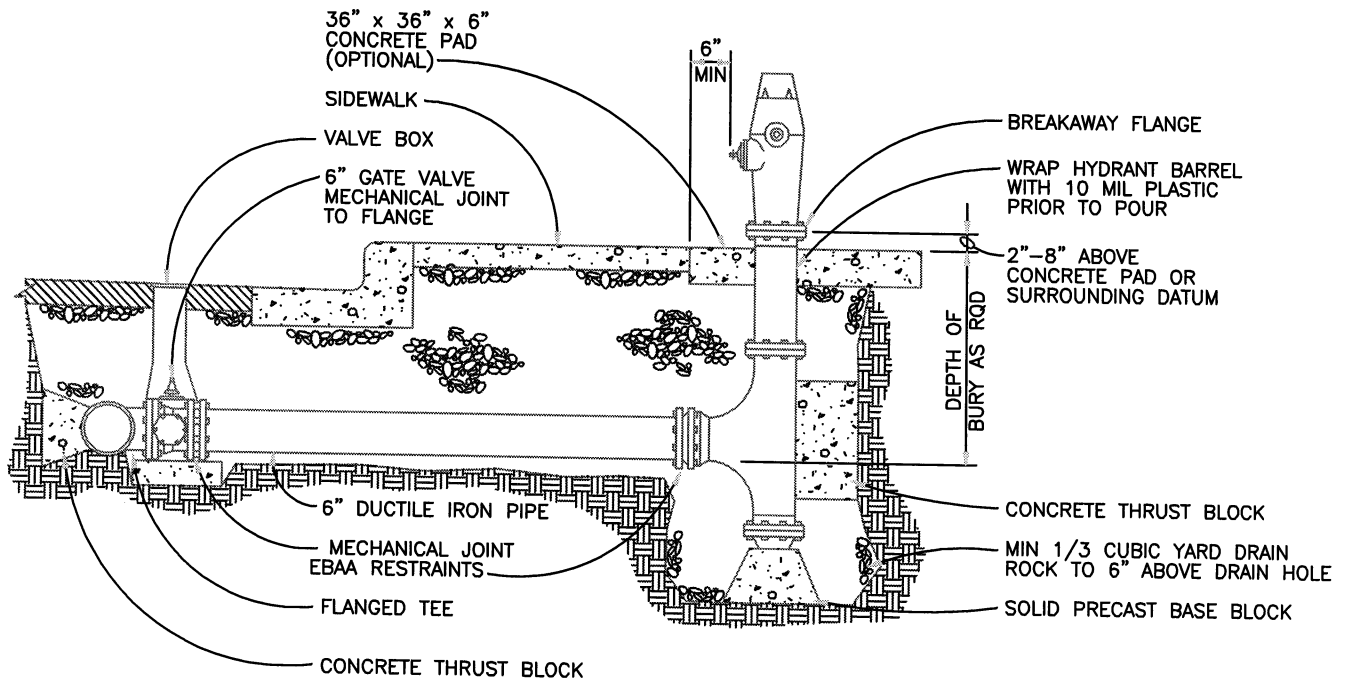

TYPICAL HYDRANT DETAIL

erd250.dgn 12-13-02

THRUST BLOCKING

CONCRETE THRUST BLOCKING (HORIZONTAL)

PIPE DIA.	Table Pressure PSI	Thrust (T) at fittings in Pounds				
		Tee & Dead Ends	90 deg Bend	45 deg Bend	22.5 deg Bend	11.25 deg Bend
4"	250	3140	4440	2405	1225	615
6"	250	7070	9995	5410	2760	1385
8"	250	12565	17770	9620	4905	2465
10"	250	19635	27770	15030	7660	3850
12"	250	28275	39985	21640	11030	5545
14"	250	38485	54425	29455	15015	7545
16"	250	50265	71085	38470	19615	9855

Soil Type	Soil Bearing Capacity (B) in PSI
Muck, peat, etc.	0
Soft Clay	1000
Sand	2000
Sand and gravel	3000
Sand and gravel cemented with clay	4000
Hard shale	10,000

CONCRETE BLOCKING FOR CONVEX VERTICAL BENDS

PIPE DIA. in.	Table Pressure PSI	DIMENSION TABLE					
		Bend Angle (deg)	Concrete Volume (cy)	Cube Size (ft)	Stirrup Dia. (in)	Stirrup Embmt. (in)	
4"	250	11.25	0.21	1.8	5/8	17	
		22.5	0.43	2.3			
		45	0.77	2.8			
6"	250	11.25	0.48	2.4	5/8	17	
		22.5	0.95	3.0			
		45	1.79	3.6			
8"	250	11.25	0.86	2.9	5/8	17	
		22.5	1.65	3.5			
		45	3.22	4.4			
10"	250	11.25	1.39	3.3	5/8	17	
		22.5	2.62	4.1			
		45	4.97	4.1			
12"	250	11.25	1.94	3.7	5/8	17	
		22.5	3.91	4.7			
		45	6.89	5.7			
14"	250	11.25	2.62	4.1	5/8	17	
		22.5	5.26	5.2			
		45	9.70	6.4			
16"	250	11.25	3.44	4.5	5/8	17	
		22.5	6.89	5.7			
		45	12.63	7.0			

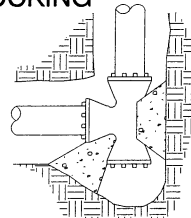

TEE

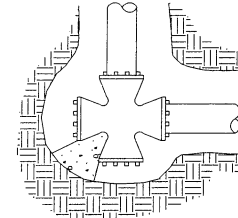

CROSS

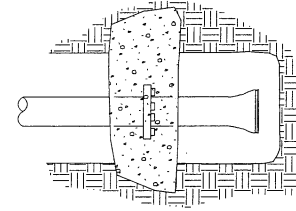

STRADDLE

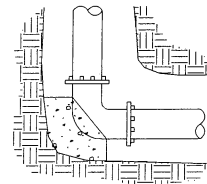

BEND

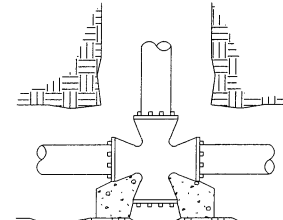

CROSS

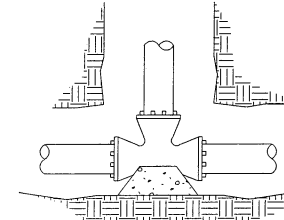

TEE

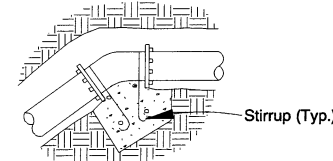

CONVEX VERTICAL BEND

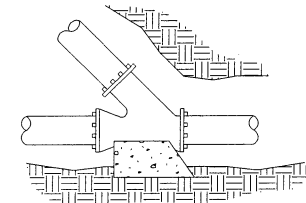

WYE

DETERMINATION OF THRUST BLOCK BEARING AREA

NOTE: WHEN THRUST BLOCK BEARING AREA IS NOT SPECIFIED ON THE PLANS OR DETERMINED BY THE ENGINEER, USE THE FOLLOWING PROCEDURE TO DETERMINE REQUIRED BEARING AREA.

- Determine thrust (T) for type of fitting or joint and size of pipe from Table.
- Determine Design (Test) Pressure from Standard Specifications or Special Provisions.
- Determine Table Pressure from Table.
- Determine Soil Bearing Capacity (B) of soil from Table.
- Determine required bearing area (A) in sq. ft. as follows:

$$A = \left(\frac{T}{B} \right) \left(\frac{\text{Design (Test) Pressure}}{\text{Table Pressure}} \right)$$

Example: Design (Test) Pressure = 150 PSI From Table, T = 272.3 PSI
 Pipe = 14" From Table, B = 14 PSI
 Fitting = Tee
 Soil = Sand

$$A = \left(\frac{38485}{2000} \right) \left(\frac{150}{250} \right) = 11.55 \text{ sq ft}$$

NOTES:

- Contractor to provide blocking adequate to withstand full test pressure.
- Divide thrust by safe bearing load to determine required bearing area (A in sq ft) of concrete to distribute load.
- Adjust bearing areas (A) for other pressure conditions. (See "Determination of Thrust Block Bearing Area" equation.)
- Pour concrete blocking against undisturbed earth.
- All concrete to be 2900 PSI minimum.
- Wrap pipe and/or fittings with 2 layers of polyethylene film where in contact with concrete.
- Keep concrete clear of all joints and accessories.
- Stirrups shall be deformed galvanized cold rolled steel AASHTO M31 (ASTM A615), Grade 420. Coat with coal tar epoxy after installation.

The selection and use of this Standard Drawing, while designed in accordance with generally accepted engineering principles and practices, is the sole responsibility of the user and should not be used without consulting a Registered Professional Engineer.

NOTE: All material and workmanship shall be in accordance with the current Oregon Standard Specifications

OREGON STANDARD DRAWINGS

THRUST BLOCKING

2002

REVISIONS

DATE DESCRIPTION

RD250

RD250

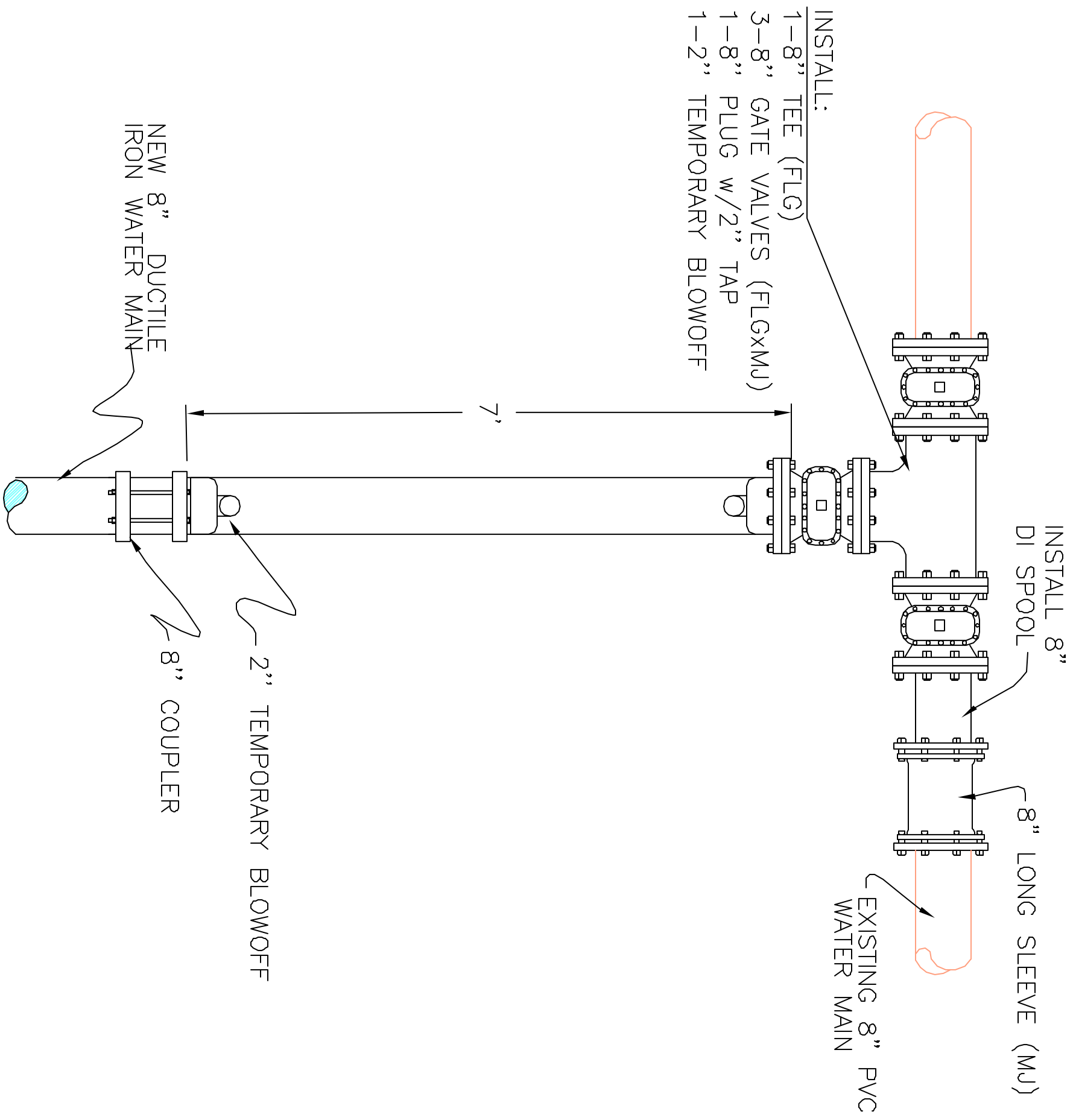

WATER TIE-IN DETAIL